

DX.DOI.ORG//10.19199/2022.165.1121-9041.050

Towards a codified design procedure for rockfall reinforced earth embankments

Rockfall protection embankments are compelling mitigation measures for those situations involving very high kinetic energy or large blocks and where the slope toe is almost flat. Several systems have been developed, and, among them, reinforced earth embankments allow considerable heights and inclination of the faces up to 70°. Nevertheless, a common procedure for including the dynamic condition, i.e. the impact, against such structures has not been delineated yet, and also the existing European Standards do not define a unique procedure. This work aims at defining a design flowchart in agreement with the Eurocodes, encompassing verifications both in static and seismic conditions and in dynamic one, i.e. when a block impacts against the structure. All the failure scenarios are considered and the embankments have to be designed first to intercept blocks. Considering the impact, an energy approach is suggested to assess the stability of the structure and a procedure to determine the displacements occurred at the impact is herein delineated. With a simple analytical solution, herein explained, the percentages of energy dissipated at the impact by plasticization or friction can be derived and used to evaluate the displacements.

Keywords: Rockfall embankments, reinforced earth, design procedure, Eurocode 7.

1. Introduction

Rockfall protection embankments (RPE) have been considered a profitable solution against rockfall events for more than 60 years, due to their ability to stop and/or deviate blocks impacting with very high kinetic energy and to sustain repeated impacts before collapse (Lorentz *et al.*, 2006; Lambert & Kister, 2017a). Their easiness of maintenance and of repair after impacts, high durability in time, as well as their reduced environmental effects represent the most recognized advantages. Nevertheless, their realization depends on the geometrical characteristics of the site, which has to be suitable for the installation of a massive ground system, considering both material retrieval and handling possibilities and the construction difficulties. Furthermore, the overall stability of the slope has to be

assured, as the huge weight of the embankment might represent an unfavourable effect.



Fig. 1 – Reinforced earth rockfall protection embankments, Cogne, Valle d'Aosta Autonomous Region, Italy.

Maddalena Marchelli*
Chiara Deangeli*

* Dipartimento di Ingegneria per l'Ambiente, il Territorio e le Infrastrutture (DIATI). Politecnico di Torino

Corresponding author:
maddalena.marchelli@polito.it

Different types of embankments have been developed during the years, differing for shape and for materials of uphill, core, and downhill faces (Hennebert *et al.*, 2014; Lambert & Kister, 2017b). Among the various solutions, the reinforced earth embankment (Fig. 1) represents a valuable type, widely adopted in rockfall hazardous areas (Peila *et al.*, 2007). This system is made up of overlaid layers of compacted soil, each wrapped in a tensile resistant element, generally a geogrid (Brunet *et al.*, 2009). Due to this, a side inclination of 70° can be reached, and, consequently, at equal self-weight, structures higher than

the simple earth ones can be realized. Despite their wide employment, a codified design procedure has not been defined yet.

The most challenging aspect in the design lies in the correct definition of the impact force and the distribution of the stresses in the structure, and thus, the resistance mechanisms. Studies related to the impact of a body against a granular medium have been carried on considering the impact of projectile and its penetration (Boguslavskii *et al.*, 1996; Walker, 2001; Ahmed *et al.*, 2020), or following the inelastic collision models (Carotti *et al.*, 2004), or based on the elastic contact Hertz model (Popov, 2010), or based on the energy balance (Wang & Caves, 2008). Some interesting findings have been obtained considering experiments and studies related to rockfall protection galleries (Schellenberg & Vogel, 2009). Nevertheless, these studies generally consider an infinite granular medium or with a rigid stratum below. Referring in particular to embankments, both experimental and numerical studies have been developed, providing several interesting suggestions. Small scale experiments have been conducted by Hofmann & Mölk (2012) on different kind of embankments, and by Kister *et al.*, (2014) on a two-dimensional framework. Real scale experiments have been performed on different types of embankments, with wooden reinforcements (Burroughs *et al.*, 1993; Hearn *et al.*, 1995), with cushion layers (Yoshida, 1999; Maegawa *et al.*, 2011; Lambert *et al.*, 2014). As long as interesting, these experiments are leading with an impact energy much lower than the capacity of the structure. Specifically considering reinforced earth embankments, Peila *et al.* (2007) and Mongiovi *et al.* (2014) have performed three and two full-scale tests, respectively, trying to

understand the behaviour of the structure against multiple impacts and until collapse. Due to the costs and operational difficulties these kinds of experiments are not easily repeatable and thus these tests constituted the basis for validation of numerical models (Castiglia, 2000; Ronco *et al.*, 2009, Ronco, 2010, Murashev *et al.*, 2013). Numerical models have been developed also for pure earth embankments (Plassiard & Donzé, 2009 and 2010; La Porta *et al.*, 2019), or other kind of embankments (Breugnot *et al.*, 2016).

At present, as reported by Lambert & Kister (2017a), besides the modelling approach, four are the main design practices for dealing with the impact: (i) mass based approaches, i.e. the embankment is assumed to be able to stop the block and withstand the impact, and thus the structure is just designed with respect to gravity loads; (ii) penetration criteria based approaches, for which the minimum embankment thickness is derived multiplying for a factor 2 or 3 the estimated value of the penetration of the block; (iii) pseudo static approaches, which considers a load that is statically equivalent to the dynamic impact for designing the embankment and thus only the structure static stability in combination with gravity loads is checked; (iv) energy approaches, which assess the ability of the embankment in withstanding the impact estimating analytically the energy dissipated within the embankment and evaluating that the consequent deformation of the structure is consistent with the embankment dimensions.

Despite all the studies and investigations, a common procedure for including the dynamic condition, i.e. the impact, against such structures has not been defined yet, as well as a universally defined flowchart for the whole de-

sign process of these structures. Also the existing European standards related to this topic as the Italian UNI 11211-4 (2018) and the Austrian ONR 24810 (2021), even providing some interesting suggestions, do not delineate a unique procedure. Among these considerations, however, they recommend evaluating the impact actions through accurate rockfall propagation analyses, which allow the estimation of the kinetic energy and height of the impacting block.

Focusing on reinforced earth rockfall protection embankments, this work aims at delineating a design procedure encompassing all the safety/stability requirements of EN 1997-1 (2004) (Eurocode 7, named EC7), based on previous findings and performing some analytical considerations. A flowchart for the design is proposed, defining all the load conditions and assessments that should be performed. Considering the embankment as a massive structure whose aim is to withstand the impact of a block with high kinetic energy, the assessment should consider the static, the seismic, and the dynamic conditions. Suggestions are provided to compute the energy dissipation and the consequent displacements induced by the impact. Finally, an example of calculation for a dynamic situation is provided.

2. Design of embankments

2.1. Regulations and Standards

Embankments are generally considered as geotechnical works, and, referring to Eurocodes (and in particular to EC7), they have been in-

served in Geotechnical Category 2, i.e. a category which should include conventional types of structure and foundation with no exceptional risk or difficult soil or loading conditions. They are specifically dealt with in Section 12, without a particular reference to rockfall protection embankments. To be fair, the term “rockfall” appears only in the paragraph 4.2.3 (Assessment of the Design), where EC7 prescribes that the assessment of the design “*should include a careful review of the most unfavourable conditions, which occur during construction with regards to [...] environmental impacts and changes including landslides and rockfalls*”.

In the framework of a limit states based design, in conjunction with a partial factor method, among the limit states indicated in the EC7, for the specific case of RPE, neglecting the presence of water, the following limit states should be verified: (i) loss of the overall stability, (ii) failure in the embankment slope or crest and (iii) deformations in the embankment leading to loss of serviceability (e.g. cracks). Moreover, as a massive structure, (iv) the bearing capacity of the subsoil should be assessed. Even if not specifically mentioned, in the specific case of RPE, the self weight, the seismic actions, and the dynamic loads (i.e. the impact) are the actions that have to be considered. No predefined design situations are reported, even though it is implicit that the effects of an impact have to be properly investigated as part of the short-term and long-term scenarios. Focusing on reinforced earth, the EC7 at Par. 9.1.2.3 requires additional verifications, such as: (v) failure of a structural element or combined failure in the ground and in the structural element, (vi) movement of the retaining structure, which may cause collapse, (vii) failure by sliding at the base; (viii)

failure by toppling. Among the actions, collision forces are also mentioned.

In the European panorama of standards and codified procedure, UNI 11211-4 (2018) and ONR 24810 (2021) are specifically for rockfall protective structure and deal with embankments.

Referring to the former, the par. 5.3.4. deals with reinforced earth RPE. The suggested verifications should encompass the stability of the work also in presence of dynamic loads, and in particular it should be assessed that: (i) the height of the embankment is such to intercept the design block; (ii) the block does not overcome the structure due to its rotational kinetic energy; (iii) the static stability also in presence of reinforcements, which have to be properly assessed; (iv) slope overall stability for the presence of the embankment; (v) correct water outflow of the slope (vi) the stability of the embankment in dynamic conditions. Referring to this last point, the UNI 11211-4 recommends to define the maximum admissible uphill penetration, such that the embankment can be repaired with reasonable costs, and the maximum downhill deformation not to provoke collapse or interference with the structures nearby. The way to determine these deformations are not defined. This consideration implicitly implies that an energy-based approach should be adopted to assess the stability of the embankments in withstanding the impact. As mentioned in the introduction, this kind of approach is based on the analytical estimations of the energy dissipated within the embankment, computed considering a zone within the RPE disturbed by the impact. The dissipative mechanisms must be defined, and the design consists in assessing that the deformations required to dissipate the impacting block

kinetic energy are consistent with the admissible ones. Based on all previous studies and experiments, the dissipative mechanisms are the energy dissipation through soil compaction and friction along shear planes, assuming the zone disturbed by the impact moves as a rigid body. Generally, to derive the uphill deformation, i.e. the block penetration, the impact force should be defined. This assumption is confirmed by the fact that the UNI 11211-4 suggests defining the performances of the RPE in terms of energy absorption capacity, computed through a standard impact test, performed according to UNI 11167 (2018).

The ONR 24810 introduces the RPE in Par. 6.3. as element able to withstand primarily the actions of an impacted block. Other actions, like avalanche, mass fall, debris flow must be considered as additional actions only where necessary. Therefore, the energy absorption capacity as well as the height are the performance characteristic of an embankment. Three design situations have to be considered: (i) verification of ultimate limit state of the structure without rockfall action, (ii) verification under construction; (iii) during the rockfall action according to an impact event (additional special loads should be verified only where necessary). Among the permitted construction type, Type IV A (geosynthetic reinforcement with “*low tensile/axial stiffness*”) and Type IV B (geosynthetic reinforcement with “*high tensile/axial stiffness*”) refer to reinforced earth RPE. The serviceability limit state is correctly verified applying the construction rules related to the compaction of the soil (with a sample Proctor density which spans from 98% to 100%), and to the height which should be such to intercept the design block, adding a proper freeboard. This last should be larger than 1.5 the de-

sign block diameter for reinforced earth RPE having an upslope face inclination of at least 60°, and one single diameter for those with an upslope inclination of at least 70°. Considering the ultimate limit state design, the creation of a failure plane inside the embankments, in the embankment and subsoil, and in the subsoil only have to be analysed, i.e. the internal and overall stability should be assessed, considering also the distribution of the actions on foundation. No specified criteria are defined. Regarding the rockfall impact, ONR 24810 implicitly suggests to adopt a pseudo static approach, providing a chart on which determining the statically equivalent force, according to the geometry of the embankment and its construction type. This chart was derived from the experiment conducted by Hofmann & Mölk (2012). Interestingly, for reinforced earth embankments subjected to an impact with a design value lower than 5000 kJ, the adoption of geometrical and soil and geosynthetic defined properties allows not to perform any calculations related to the dynamic impact.

It is worth mentioning that both Italian and Austrian Standards recommend to perform trajectory analyses to evaluate the kinetic energy and height of the blocks at the impact, and, in the framework of a partial safety based design approach, provide suggestions for the percentiles to consider as characteristic values, and for the partial safety factors. In particular, UNI 11211-4 adopts the 95th percentile for both the quantities, while ONR 24810 the 95th for the height and 99th for the energy. Different partial safety factors are adopted: fixed values in UNI 11211-4, based on the uncertainties related to propagation model and available input parameters, while values accounting for the event frequency and the

consequences class in ONR 24810. Similar considerations can be done for the design block volume, which has to be taken equal or greater than the 95th percentile of the distribution at the slope toe in the UNI 11211, and with a variable percentile in ONR 24810, accounting again for the frequency of the event and the possible damages.

Based on all these specifications, a design procedure accounting for the whole design situations and verifications required in the Eurocode framework is defined below, subdividing for static, seismic, and dynamic (impact) situations. For each critical load case, the design values of the effects of actions shall be determined by combining the values of actions that are considered to occur simultaneously.

2.2. Static and seismic design situations

Based on the previous preliminary considerations, RPE should be verified both in static and seismic design situations. The term “static design situation” refers generally to the persistent design situation, i.e. related to the condition of normal use. Also a transient design situation, i.e. a temporary condition during execution or repair, can be evaluated in the static case. The fundamental combination of actions is considered, i.e. the one accounting for the gravity load, eventually permanent loads, the leading and the accompanying variable actions. Relating to these lasts, the influence of the snow or the wind can usually be neglected.

In the seismic design situation, the combination of actions accounts for the gravity and the seismic load. Referring to the common design practice, the seismic load is composed vertical and horizontal forces proportional to the mass of the embankment and to

the site parameters (location and site effects).

In the framework of the partial safety factor design approach, the ultimate limit state design verifications that have to be considered are: (i) failure by sliding at the base; (ii) bearing resistance failure of the soil below the base; (iii) failure by toppling; (iv) ground-embankment overall stability; (v) failure of the structural elements, i.e. the reinforcements.

As related to the loss of equilibrium of the structure or the ground as a rigid body, the overall stability (iv) is related to an equilibrium ultimate limit state (EQU), while (v) to a structural one (STR), being associated to an internal failure. The other three verifications (i, ii, iii) represent instead a geotechnical ultimate limit state (GEO), related to the failure or excessive deformation of the ground. According to the ultimate state type the proper design approach, i.e. the proper set of partial safety factors, should be adopted.

It reveals that in the persistent design situation, sliding at the base as well as toppling are generally neglected (Comedini & Riboldi, 2014).

2.3. Dynamic design situations

The dynamic design situation represents the one in which the embankment is subjected to the impact of a block. In the Eurocode, this can be considered as an accidental situation, which refers to exceptional conditions, even though it could be inferred that for a RPE impacts should be considered as a persistent action. Nevertheless, as the assumed design block and its design kinematic parameters are representative of a condition with a very large return period, at least if compared with the design working life of the

structure, this situation can be ascribed as accidental.

Considering the occurrence of a rockfall event, according to UNI 11211-4, three are the possible failure modes: (i) the block overcomes the embankment, with or without impacting against the embankment; (ii) the block, impacting on the structure, causes an excessive deformation or the collapse of the structure itself, (iii) the slope-structure system collapses due to the impact.

Evaluating each mode separately, three are the possible scenarios leading to the first mode: (i) the block passing height is higher than the embankment, or, after the impact, (ii) the block rolls over the upstream face, or (iii) the block separates into fragments and some of them jump over the upstream face. It has been observed that in case of reinforced earth embankments, the impact produces a crater and remains bounded by the soil, thus the spinning force required to self-extract is generally very large. Similarly, possible fragments generally are not able to overcome the structure. For this reason, the (ii) and (iii) scenarios are commonly neglected. The first scenario is thus prevented if the following inequality holds:

$$H_e \geq h_d + f \tag{Eq. 1}$$

where H_e is the height of the embankment, h_d the design value of the block passing height and f a tolerance, accounting for the block size. The Author suggests embedding in the tolerance also the height of a layer, h_l , as an impact in the very top layer of the structure could cause the collapse of the top layers (Mongioli *et al.*, 2014). It can be stated that the height of the embankment is the first parameter to be chosen in the design process.

Referring to the second failure mode, i.e. the excessive deforma-

tion or collapse of the structure, two are the possible scenarios at the impact: (i) the block creates a deformation on both the upslope and downslope faces in such a way that the impacted layers deform, slide and eventually collapse; (ii) the block passes through the embankment due to penetration and puncture. To control and prevent the occurrence of this failure mode, the deformations of both sides due to impact should be computed and compared with the admissible displacements. Hence, the following conditions should be

verified:

$$\delta_p + \delta_s < X_g \tag{Eq. 2}$$

$$\delta_p \leq 0.7 l_{flap} \tag{Eq. 3}$$

where δ_p and δ_s are the deformations on the uphill and downhill faces, respectively, both measured as the maximum displacement in the direction normal to the cross-section, X_g is the x-coordinate of the centre of gravity of the layers above the impacted ones, measured by their uphill edge as sketched in Figure 2, l_{flap} is the length of the reinforcement flap. Eq. 2 refers to

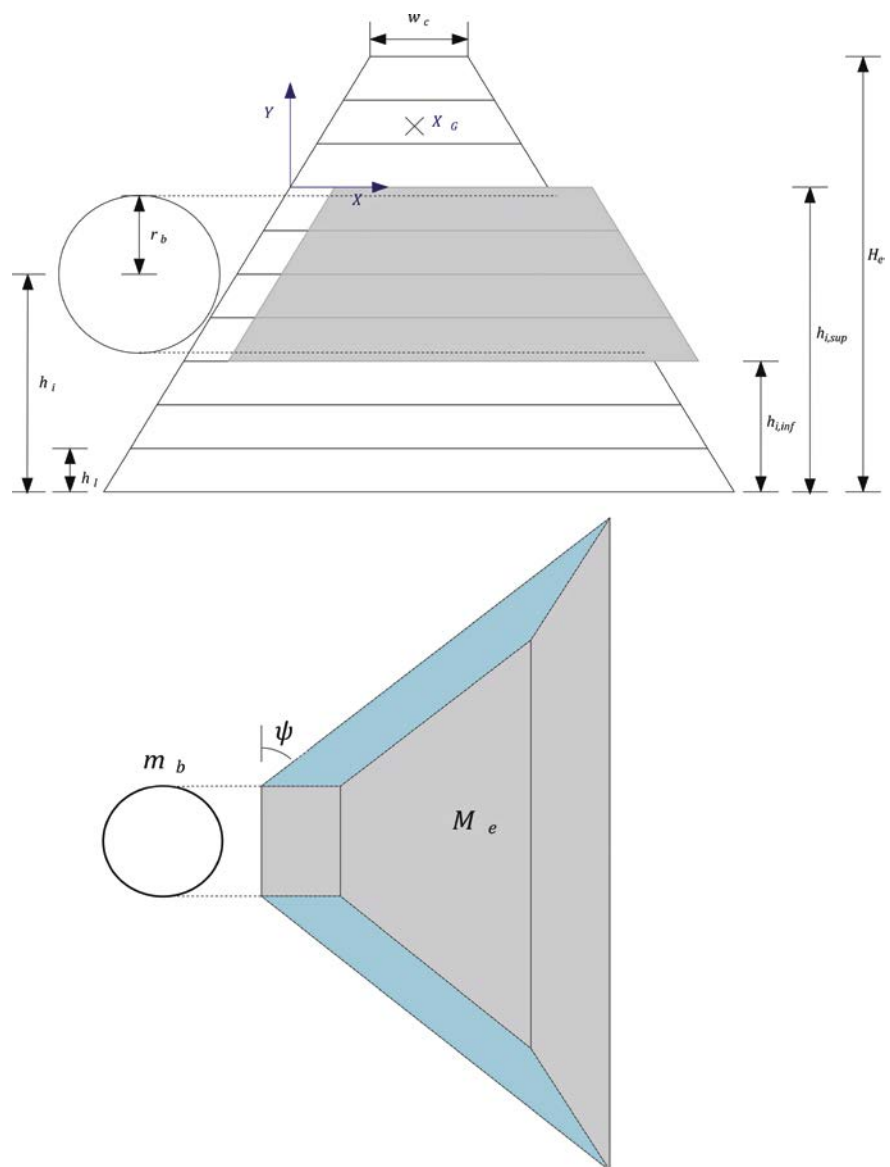

Fig. 2 – Sketch of the considered impact configuration. The white faces represent the planes in which friction forces can be added in computing F_f . The blue X and Y axes serves to evaluate X_g of Eq. 2.

the collapse of the upper part of the structure, while (Eq. 3) to the collapse of the downhill face due to lost of containment of the soil. The analytical evaluation of the displacements represents the most challenging aspect, and many authors have provided different solutions derived from different assumption, or different models. As an example, different formulation has been proposed to calculate the maximum penetration δ_p , derived from experiments related to a rockfall protection tunnel (Labieuse *et al.*, 1996; Montani, 1988; Di Prisco & Calvetti, 2007), or from military experiments related to the impact of projectiles on earth structures (Kar, 1978), or derived from numerical simulations (Grimod & Giacchetti, 2013). The method herein suggested is derived from the works of Peila *et al.* (2007) and Ronco *et al.* (2009).

Starting from the energy balance assumption, in the hypothesis that the impacting element is stopped by the embankment, the kinetic energy E_k of the block is balanced by the dissipated energy, which occurs through (i) soil compaction and (ii) friction along preferential sliding planes (Peila *et al.*, 2007; Ronco *et al.*, 2009), assuming that the impacted layers move as rigid bodies, i.e.

$$E_k = E_p + E_f \quad (\text{Eq. 4})$$

where E_p and E_f are the energies involved for plasticization (soil compaction) and friction, respectively. The recoverable strain energy can be neglected in a first approximation. Experiments on real structures show that, once impacted, the layers of the embankment keep their trapezoidal geometry thanks to the geogrids and reciprocally slide along the reinforcement interfaces. Referring to the friction, the sliding planes are represented by the lower face of the lowest impacted layer and the upper face of

the highest impact layer. It is thus considered that all the impacted layers slide downhill together with the block. A lateral diffusion is considered, with an angle ψ in the impact direction of around 45° , as confirmed by experiments and numerical models (Ronco *et al.*, 2009). The mass of the embankment involved during the impact M_e is, thus, a prism with trapezoidal bases.

Deformations can be evaluated by the ratio of the energies involved in each dissipative mode and the correspondent resistant force, both for soil compaction F_p and friction F_f , i.e.

$$\delta_p = \frac{2E_p}{F_{p,max}} \quad (\text{Eq. 5})$$

$$\delta_s = 2 \frac{E_f}{F_f} \quad (\text{Eq. 6})$$

For the former, (Eq. 5), it is assumed that a linear compaction force – displacement relationship holds and a maximum force $F_{p,max}$ is reached. The latter, Eq. 6, derives from the relationship $E_f = F_f \delta_s$ considering a dynamic amplification factor equal to 2 to account for the impulsive nature of the impacting force. The evaluation of $F_{p,max}$ represents a crucial issue, and various formulations have been adopted. A good agreement with experiments has been achieved with the formulation proposed by Montani (1998), i.e.

$$F_{p,max} = 2.8t^{-0.5}r_b^{0.7}M_E^{0.4}\tan\phi E_p^{0.6} \quad (\text{Eq. 7})$$

where t is the thickness (in meters) of the compactable part, r_b the block radius (in meters), M_E the elastic modulus of the soil (in kPa), and ϕ the internal friction angle. The energy dissipated through soil compaction E_p is measured in kJ. This formulation was derived for rockfall protection gal-

leries, where t represents the width of soil over the concrete slab; in the present case, it is assumed that half of the width of the embankment at the location of the impact serves as a buttress, in the direction of the impact, and thus only half can be compacted. The friction force F_f is evaluated considering the normal force due to self-weight of the embankment. Friction occurs along the basal and the upper planes of the sliding layers assuming a transversal diffusion angle ψ . The amount of kinetic energy dissipated through soil compaction or sliding depends on many variables related to the geometry of the embankment, as detailed in Sec. 2.3.1. It is worth noting that in cases of blocks with a diameter comparable with the embankment height, the embankment itself tends to slide without compaction.

Considering the last failure mode, i.e. an overall instability, the generally adopted method consist in considering a static equivalent force to represent the impact and performing the usual calculations for the overall stability verification. To compute this force, an expression equivalent to that proposed in (Eq. 7) can be adopted, considering E_k instead of E_p .

Finally the reinforcements should be assessed both in static and seismic and in dynamic conditions. In particular, they have to be verified against tensile and pull out forces (Comedini & Rimoldi, 2014) due to the weight of the earth above the considered reinforcement, the seismic actions, and the dynamic impact generally assumed as a static equivalent force.

2.3.1. Energy dissipation

Based on both real scale experiments and numerical analyses, Ronco *et al.* (2009) found that E_p is

80-85% of E_k . Similar values were obtained from small scale experiments (Hofmann & Mölk, 2012), while from those of Kister *et al.* (2017) E_p ranges between 75% and 85% of E_k . The values suggested in the literature are derived from the experimental setups and considering general adopted embankment geometries, thus they are inherently appropriate for a limited range of RPE. To overcome this limitation, a simple physical model, able to quantify the amount of kinetic energies that are dissipated through soil compaction or friction, is herein proposed.

These findings can be also confirmed by a simple analytical approach, herein proposed, which confirm that even though the proposed values are true in almost the cases, a specific value of the ratio between E_p and E_k can be easily obtained and adopted. The evaluation of percentage of the energy dissipated by friction can be achieved by means of the momentum conservation principle. The assumption of a completely inelastic impact can be considered representative as during the sliding motion the block and the disturbed portion of the embankment are supportive each other. Defined m_b and v_{in} the mass and impact velocity of the block, M_e the mass of the embankment disturbed by the impact, the following equation can be written:

$$m_b v_{in} = (m_b + M_e) v_{out} \quad (\text{Eq. 8})$$

where v_{out} is the sliding velocity of the block and moving embankment, which kinetic energy can be easily computed. Rearranging the mathematical expressions, the percentage of the kinetic energy of the block $E_{k,in}$ converted during the impact in kinetic energy of the block and the moving part of the embankment and, thus, dissipated by friction, i.e. α_f , can be obtained as:

$$\alpha_f = \frac{E_f}{E_k} = \frac{m_b}{m_b + M_e} \quad (\text{Eq. 9})$$

which is independent from the initial velocity. Thus, it results:

$$E_f = \alpha_f E_k \quad (\text{Eq. 10})$$

$$E_p = (1 - \alpha_f) E_k \quad (\text{Eq. 11})$$

The formulae previously proposed have been applied to the published case studies (Ronco *et al.*, 2009; Hofmann & Mölk, 2012; Kister *et al.*, 2017) and a good agreement is found.

2.3.2. Sensitivity analysis

Starting from the previous findings, a sensitivity analysis is performed, aimed at individuating the typical ranges of α_f , varying both the block radius and the geometry of the embankment. Referring to this last, the considered variable is the width of the crest w_c . A typical embankment geometry is considered, whose parameters are listed in Table 1. Referring to the impact, it is considered that it occurs at embankment mid-height. The maximum impacting block radius r_b is set to follow the constraints of (Eq. 1).

Figure 2 depicts the zone disturbed by the impact. The block is assumed with a round shape and

the size of embankment affected by the impact (from which M_e is computed) is derived with reference to a square cross section area of about $2r_b \times 2r_b$. Due to the difficulties in estimating the correct lateral friction forces, the interaction on the top and bottom surfaces is considered, only, as represented in white in Figure 2.

Figure 3 represents the value of α_f i.e. the percentage of kinetic energy dissipated by friction, as obtained by the sensitivity analyses. It can be observed that for very small blocks, the energy contribution of the friction is negligible, and only a formation of a crater occurs. On the contrary, very large blocks with small width of the crest generate a dissipation up to 25% of the kinetic energy through friction. It is worth mentioning that if the block size would not be limited as to satisfy (Eq. 1), i.e. the block diameter is similar to the height of the embankment, an entire portion of the embankment will slide. Nevertheless, this last phenomenon should be avoided. The non-smooth transitions between the contour zones are due to the discrete number of sliding layers, as each layer impacted by the block is assumed to be entirely involved in the motion. This study thus reveals that in general, a value α_f in

Tab. 1 – Input parameters of the sensitivity analysis.

Parameter	Value
Embankment height H_e	6 m
Height of each layer h_l	0.6 m
Uphill face slope angle	60 °
Downhill face slope angle	60 °
Crest width w_c	in the range from 1 m to 3 m
Length of the flap l_{flap}	1 m
Elastic modulus of the soil M_E	25 MPa
Internal friction angle ϕ	30°
Friction coefficient at the layers surfaces μ	0.45
Height of impact h_i	3 m
Block radius r_b	in the range from 0,5 m to 2,4 m

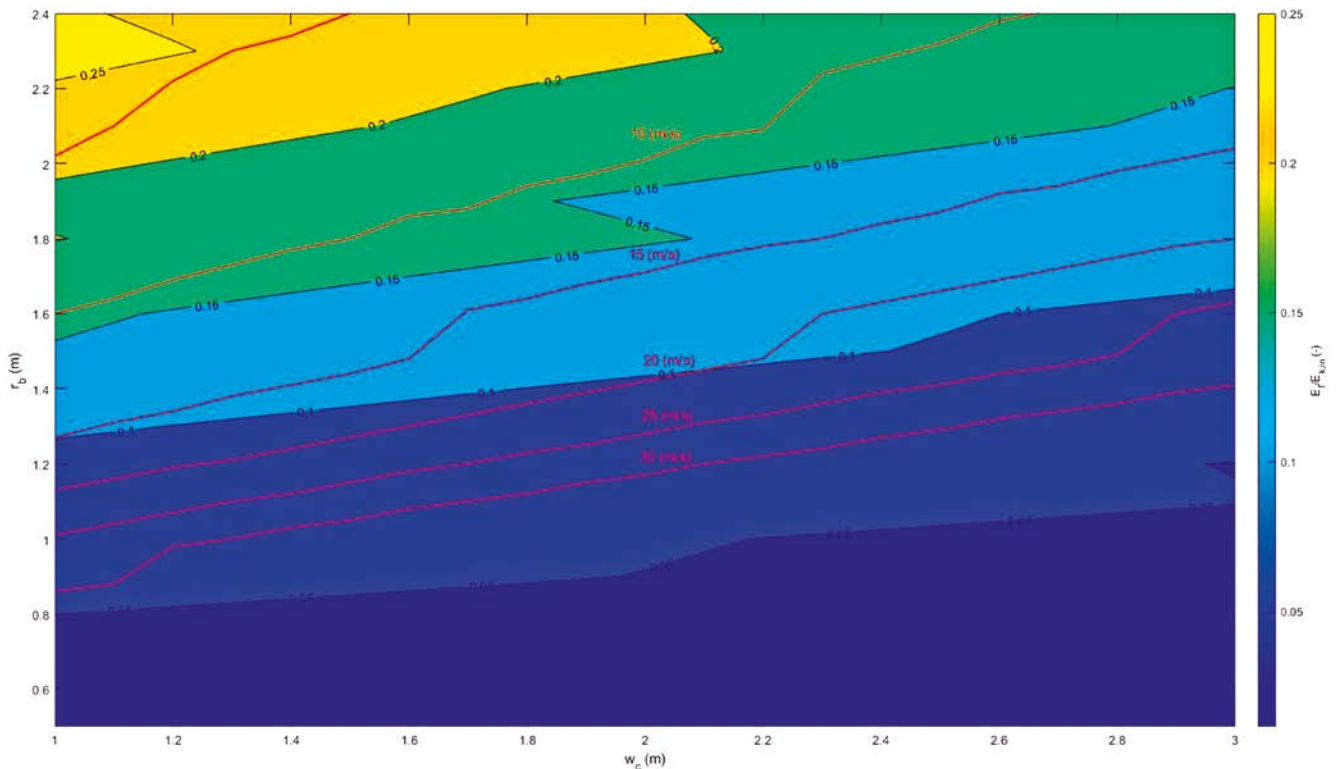

Fig. 3 – Contour plot of the percentage α_f of kinetic energy dissipated through friction along the sliding planes. Red curves relate to the limit values of w_c and r_b for each block velocity required to satisfy (Eq. 2) and (Eq. 3).

the range 0% (for small impacting blocks) to 25% (for large blocks) encompasses all the possible cases. Considering thus a l_{flap} equal to 1 m, the limit (r_b, w_c) pairs that satisfy both (Eq. 2) and (Eq. 3), can be computed for various impacting velocities. This analysis is reported in red in Figure 3 for different velocities in the range 5 m/s to 30 m/s. The feasible earth reinforced embankments geometries are those below the curves. For very high velocities of the block, it seems that the allowable energy dissipated by friction should be lowered, i.e. the allowable displacement δ_s should be decreased. The present sensitivity analysis is based on layer, soil and reinforcement properties defined in Table 1. Similar, but different, results can be drawn if other properties are considered.

2.3.3. Example

This section proposes an example of design considering the dynamic situation. The impact parameters

of the block are listed in Table 2. It is worth noting that the kinematic parameters of the block are reported in terms of design values, according to the Eurocodes. In compliance with Eq. 1, an embank-

Tab. 2 – Input parameters of the block and geometrical characteristics of the embankment.

Parameter	Value
Block radius r_b	1.2 m
Height of impact $h_{i,d}$	2.42 m
Velocity of impact $v_{i,d}$	25 m/s
Embankment height H_e	4.8 m
Height of each layer h_l	0.6 m
Uphill face slope angle	60 °
Downhill face slope angle	60 °
Crest width w_c	2 m
Length of the flap l_{flap}	1 m
Elastic modulus of the soil M_E	25 MPa
Internal friction angle ϕ	30°
Friction coefficient at the layers surfaces μ	0.45

ment height $H_e = 4.8$ m is selected, according to the generally adopted height of each layer h_l , i.e. 60 cm. Following the results plotted in Figure 3, as the same soil and reinforcement characteristics of the former analysis are considered, a crest width w_c of 2 m is adopted. Table 3 depicts the obtained results following the calculation listed in Sec. 2.3.

Tab. 3 – Results of the design analysis.

Parameter	Value
Impact kinetic energy E_k	6107 kJ
α_f	0.095
Energy dissipated by friction E_f	581 kN
Energy dissipated by compacting E_p	5527 kN
F_f	1698 kN
F_p	12048 kN
Displacement δ_p	0.92 m
Displacement δ_s	0.68 m
X_g	1.68 m

3. Conclusions

Among rockfall mitigation measures, protection embankments are widely adopted, especially for those situations in which very high kinetic energies or very large blocks are involved and where the slope toe is almost flat. Among the different risk mitigation measures, reinforced earth embankments represent a powerful solution, allowing considerable heights and inclinations of the faces up to 70°. Despite their wide adoption, a codified design procedure against impacts has not been defined yet. In the framework of the Eurocodes, this work proposes a design flowchart, encompassing verifications both in static and seismic conditions and in dynamic one, i.e. when a block impacts on the structure.

The first step consists on the choice of the embankment height in order to intercept the blocks, whose trajectories should be determined by accurate propagation analyses. Then, an energy approach is suggested and a procedure to determine the displacements due to the impact is delineated. The kinetic energy of the block is mainly dissipated in compaction of the impacted soil with the formation of a crater, while a lower contribution is provided by the friction at the interfaces along which sliding phenomena occurs. It is supposed that the impacted layers move as a rigid bodies, together with the block, and the perturbation diffuses laterally creating a prism with trapezoidal bases.

With a simple analytical solution, herein delineated, the percentages of energy dissipated by plasticization or friction can be derived and used to obtain the displacements through the knowledge of the exerted forces. The obtained displacements are then compared to those defined as admissible for the stability of the embankment.

Finally, with a pseudo-static approach, the overall stability of both the slope and the structure has to be assessed. Further developments would concern the computation of the plasticization force during the impact or the definition of a design procedure according to a reliability based approach (De Biagi *et al.* 2020; Marchelli *et al.* 2021).

References

- Ahmed, M., Al Qadhi, S., Mallick, J., Desmukh, M.N., & Hang, H.T., 2020. *Advances in projectile penetration mechanism in soil media*. Applied Sciences, vol. 10, n. 19, pp. 28.
- Boguslavskii, Y., Drabkin, S., Juran, I., & Salman, A., 1996. *Theory and practice of projectile's penetration in soils*. Journal of geotechnical engineering, vol. 122, n. 10, pp. 806-812.
- Breugnot, A., Lambert, S., Villard, P., Goteland, P., 2016. A discrete/continuous coupled approach for modeling impacts on cellular geostructures. *Rock Mechanics and Rock Engineering*, vol 49, n. 5, pp. 1831-1848.
- Brunet, G., Giacchetti, G., Bertolo, P., & Peila, D., 2009. *Protection from High Energy Rockfall Impacts Using Terramesh Embankments: Design and Experiences*. In: 60th Highway Geology Symposium, pp. 107-124.
- Burroughs, D.K., Henson, H.H., Jiang, S.S., 1993. *Full scale geotextile rock barrier wall testing, analysis and prediction*. Proceedings of Geosynthetics '93, Vancouver, Canada, 959-970.
- Carotti, A., di Prisco, C., Vecchiotti, M., Recalcati, P., Rimoldi, P., 2004. *Modeling of geogrid reinforced embankments for rockfall protection*. Proceedings of the 3rd European Geosynthetics Conference, Munich, Germany, pp. 675-680.
- Castiglia, C., 2000. *Studio del comportamento di rilevati paramassi*. Master Thesis, Politecnico di Torino, Torino.
- Comedini, M., & Rimoldi, P., 2014. *Terre rinforzate: Applicazioni, tecnologie, dimensionamento*. Dario Flaccovio Editore.
- De Biagi, V., Marchelli, M., & Peila, D., 2020. *Reliability analysis and partial safety factors approach for rockfall protection structures*. Engineering Structures, 213, 110553
- Di Prisco, C., & Calvetti, F. (2007). *Linee guida per la progettazione di gallerie paramassi*. Starrylink Editrice Brescia, Brescia.
- D.M. 17 gennaio 2018. *Aggiornamento delle «Norme tecniche per le costruzioni»*.
- EN 1997-1:2004, 2004. Eurocode 7 – geotechnical design. part 1: General rules.
- Grimod, A., & Giacchetti, G., 2013. *Protection from High Energy impacts using reinforced soil embankments, Design and experiences*. Landslide Science and Practice, vol. 3, pp. 189-196.
- Hearn, G., Barrett, R.K., Henson, H.H., 1995. *Development of effective rockfall barriers*. Journal of transportation engineering, vol. 121, n. 7, pp. 507-516.
- Hennebert, P., Lambert, S., Fouillen, F., & Charrasse, B., 2014. *Assessing the environmental impact of shredded tires as embankment fill material*. Canadian Geotechnical Journal, vol. 51, n. 5, pp. 469-478.
- Hofmann, R., Mölk, M., 2012. *Bemessungsvorschlag für Steinschlag-schutzdämme*. Geotechnik, vol. 35, n. 1, pp. 22-33.
- Kister, B., Lambert, S., Loup, B., 2017. *Impact tests on small scale embankments with rockery-Lessons learned*. In Rocexs 2017 (pp. 4-p).
- Kar, A.K. 1978. *Projectile penetration into buried structures*. Journal of Structural Division, vol. 104, n. 1, pp. 125-139.
- La Porta, G., Lambert, S., & Bourrier, F., 2019. *DEM modeling of rockfall rebound on protective embankments*. In: 6th International Conference on Particle-Based Methods. Fundamentals and Applications, pp. 238-249.
- Labieuse, V., Descoeudres, F., & Montani, S., 1996. *Experimental study of rock sheds impacted by rock blocks*.

- Structural Engineering International: Journal of the International Association for Bridge and Structural Engineering, vol. 6, n. 3, pp. 171-176.
- Lambert, S., Heymann, A., Gotteland, P., Nicot, F. 2014. *Real-scale investigation of the kinematic response of a rockfall protection embankment*. Natural Hazards and Earth Systems Science, vol. 14, pp. 1269-1281.
- Lambert, S., and Kister, B., 2017a. *Analysis of Existing Rockfall Embankments of Switzerland (AERES); Part A: State of Knowledge*. Federal Office for the Environment, Bern, pp. 1-55.
- Lambert, S., and Kister, B., 2017b. *Analysis of Existing Rockfall Embankments of Switzerland (AERES); Part B: Analysis of the collected data and comparison with up-to-date knowledge*. Federal Office for the Environment, Bern, pp. 1-21.
- Lorentz, J., Donzé, F.-V., Perrotin, P., & Plotto, P., 2006. *Experimental study of the dissipative efficiency of a multilayered protective structure against rockfall impact*. *Revue Européenne de Génie Civil*, vol. 10, n. 3, pp. 295-308.
- Maegawa, K., Tajima, T., Yokota, T., Tohda, M., 2011. *Slope-rockfall tests on wall embankments reinforced with geosynthetics*. Proceedings of the 6th international structural engineering and construction conference, Zürich, Switzerland, 641-646.
- Marchelli, M., De Biagi, V., & Peila, D. 2021. *Reliability-based design of rockfall passive systems height*. International Journal of Rock Mechanics and Mining Sciences, 139, 104664.
- Mongiovi, L., Bighignoli, M., Danzi, A. and Recalcati, P. 2014. *An impact test on a reinforced earth embankment*. Proceedings of Interdisciplinary workshop on rockfall protection – Rocexs 2014, Lecco, Italy.
- Montani, S., 1998. *Sollicitation dynamique de la couverture des galeries de protection lors de chutes de blocks*. PhD thesis, EPFL Lausanne, Switzerland.
- ONR 24810, 2021. *Technical protection against rockfall – terms and definitions, effects of actions, design, monitoring and maintenance*.
- Peila, D., Oggeri, C., & Castiglia, C., 2007. *Ground reinforced embankments for rockfall protection: Design and evaluation of full scale tests*. Landslides, vol. 4, n. 3, pp. 255-265.
- Peila, D., 2011. *Ground reinforced embankments for rockfall protection: From real scale tests to numerical modelling*. In: Lambert, S., Nicot, F. (Eds), *Rockfall engineering*. John Wiley and Sons, New York, ISTE Ltd, London, 393-426.
- Plassiard, J.-P., Donzé, F.-V., 2009. *Rockfall impact parameters on embankments: a discrete element method analysis*. Structural engineering international, vol. 19, n. 3, pp. 333-341.
- Plassiard, J.-P., Donzé, F.-V., 2010. *Optimizing the design of rockfall embankments with a discrete element method*. Engineering Structures 32, vol. 12, pp. 3817-3826.
- Popov, V.L., 2010. *Contact Mechanics and Friction, physical principles and applications*. Springer-Verlag, Berlin.
- Ronco, C., Oggeri, C., Peila, D., 2009. *Design of reinforced ground embankments used for rockfall protection*. Natural hazards and earth system sciences 9, 1189-1199.
- Ronco, C., 2010. *I rilevati in terra rinforzata utilizzati per la protezione dei versanti: verifiche numeriche e analitiche di supporto alla progettazione*. Ph.D. Thesis, Politecnico di Torino, Torino.
- Ronco, C., Oggeri, C., Peila, D., Bertolo, P., Ferraiolo, F., Giacchetti, G., 2010. *Numerical modeling of ground reinforced embankments used for rockfall protection*. Proceedings of the 3rd Euro Mediterranean Symposium on Advances in Geomaterials and Structures-AGS 2010, Djerba, Tunisia, vol. 2, 269-276.
- Schellenberg, K., & Vogel, T., 2009. *A dynamic design method for rockfall protection galleries*. Structural Engineering International, vol. 19, n. 3, pp. 321-326.
- UNI 11167, 2018. *Opere di difesa dalla caduta massi – Rilevati paramassi – Metodo di prova all'impatto e realizzazione*.
- UNI 11211-4, 2018. *Opere di difesa dalla caduta massi – Parte 4: Progetto definitivo ed esecutivo*.
- Yoshida, H., 1999. *Recent experimental studies on rockfall control in Japan*. Proceedings of the Joint Japan-Swiss Scientific Seminar on Impact load by rock fall and design of protection structures, Kanazawa, Japan, 69-78.
- Walker, J.D., 2001. *Hypervelocity penetration modeling: momentum vs. Energy and energy transfer mechanisms*. International journal of impact engineering, vol. 1, pp. 734-743.
- Wang, B., & Cavers, D.S., 2008. *A simplified approach for rockfall ground penetration and impact stress calculations*. Landslides, vol. 5, pp. 305-310.

Acknowledgements

This work was supported by Regione Autonoma Valle d'Aosta in the framework of the project ALCOTRA RISK-ACT (n. 4980) "Azioni esemplari di resilienza dei territori transfrontalieri per far fronte ai rischi naturali in montagna".